

GREATORK

Flange structures and dimensions of AVAR

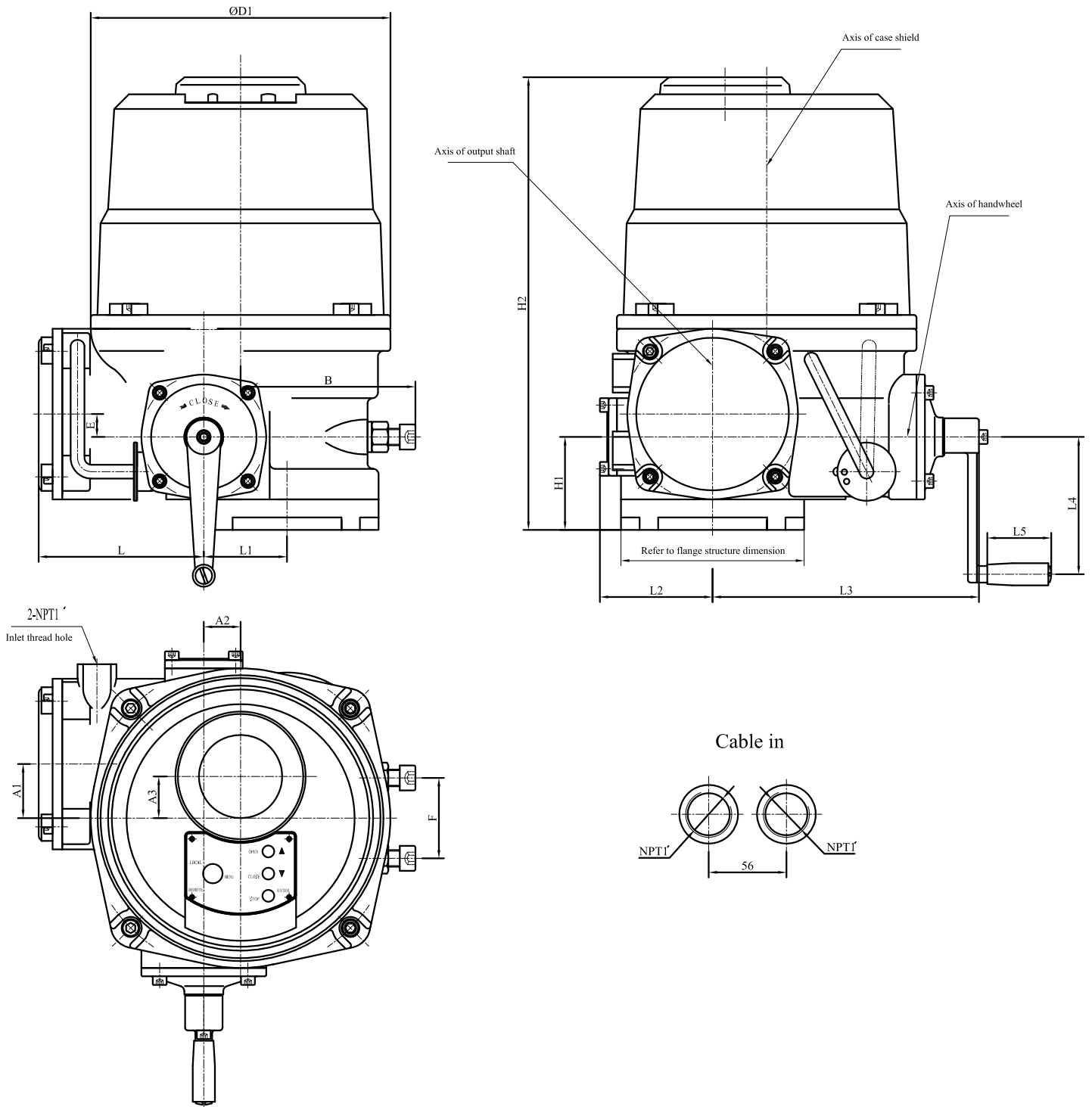

Outline Table

Code Type	A1	A2	A3	B	ØD1	E	H1	H2	L	L1	L2	L3	L4	L5	F
AVAR5 AVAR10 AVAR15 AVAR20	35	26.5	30	90	170	16.5	67	323	122	45	68	143	100	44	42

GREATORK

Flange structures and dimensions of AVAR

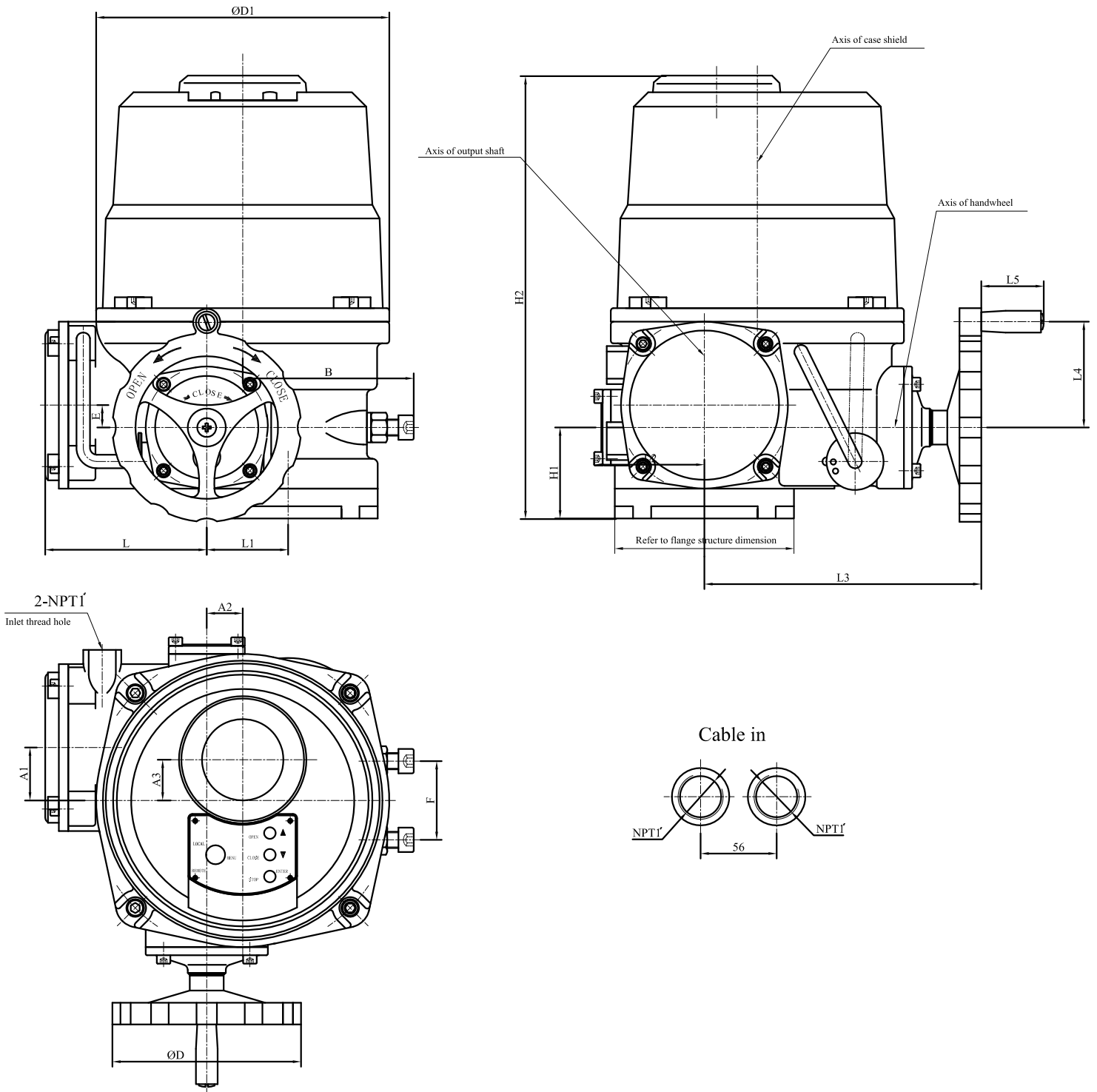

Outline Table

Code Type	A1	A2	A3	B	ØD	ØD1	E	H1	H2	L	L1	L2	L3	L4	L5	F
AVAR30 AVAR40 AVAR50	39	26.5	30	120	200	216	16.5	67	321	119	60	82	204	78	44	58

GREATORK

Flange structures and dimensions of AVAR

Flange view

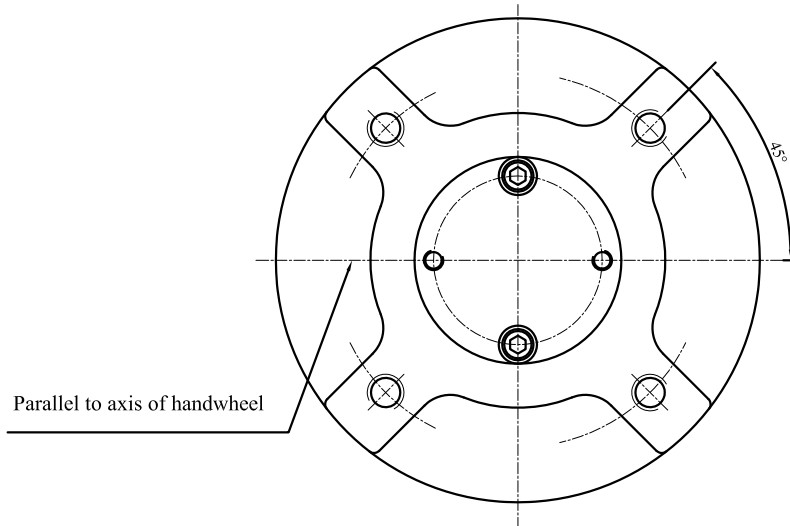

Flange section view

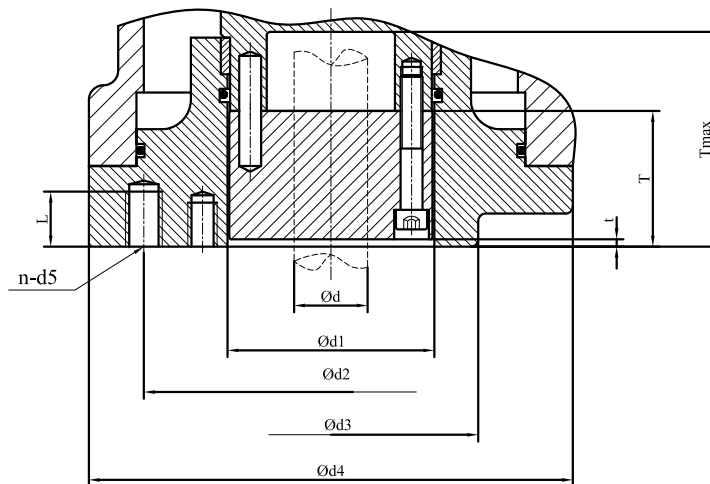

Flange dimension table

Code Type	Flange code	Ød1	Ød2	Ød (max)	Ød3	Ød4	t	T	Tmax	n-d5	L
AVAR5	F05	41	50	22	70	114	3	35	68	4-M6	12
AVAR10	F07		70								
AVAR15 AVAR20											
AVAR30	F07	56.4	70	33	80	132	2	37	72	4-M8	12
AVAR40	F10		102								
AVAR50											